

## Description

Calorimetric Flow Monitor suitable for monitoring the flow of liquids and gases, with one switch point (either MIN or MAX). Designed for rail mounting.

## Features

- Adjustable to wide range of flow rates
- No moving parts in the flow stream
- Operation largely independent of pipe diameter
- LED status indication
- Relay output for flow (MIN or MAX switching point)
- Pressure resistant monitoring head
- Fast response time
- Wire break sensing included



**SFW209**

## TECHNICAL DATA

General data		SFW209 rail-mounted
Suitable for		liquids or gases
Monitoring function	flow rate	1 switching point (MIN or MAX)
	wire break/circuit failure	standard
Display	flow rate	2 LEDs (green + red)
Temperature range	gas/liquid	-40 °C ... +100 °C / -40 °F ... +212 °F
	electronic control unit	-10 °C ... +45 °C / +14 °F ... +113 °F
<b>Electrical data</b>		
Supply voltage		AC 230/115/24 V +10 %, -15 %; DC 24 V ±10 %
Power consumption		ca. 1,5 VA
Relay outputs	flow rate	1 switching point, AC 250 V/DC 28 V, maximum load 2 A
<b>Flow monitoring</b>		
Flow response level adjustment (steplessly by means of a potentiometer)		liquids: 0,01 m/s ... 4 m/s / 0.0328 fps ... 13.1 fps gases: 0,5 m/s ... 50 m/s / 1.64 fps ... 164 fps
Repeatability <sup>(1)</sup>		± 3 %
Response delay <sup>(2)</sup>		water: 2 s, oil: 4 s, air: 7 s
Switch point drift through temperature change of the medium		approx. ± 0,7 %/°C / 1,26 %/°F
<b>Mechanical data</b>		
Type and size of monitoring head		G1/2A, 1/2"NPT, push-in type MKV
Pressure resistance	MK- and MKV monitoring heads <sup>(3)</sup>	100 bar/1450 psi
Degree of protection	monitoring head	IP67 (connector)
	electronic control unit	IP20
Materials	fitting/sensor support	stainless steel DIN 1.4571/AISI 316 Ti
	sensor	stainless steel DIN 1.4571/AISI 316 Ti
	seals	laser welded
	electronic control unit	Polycarbonate, blue
Housing dimensions (electronic control unit)		120 x 73,2 x 45 mm / 4.72 x 2.88 x 1.77 in.
Cable	standard (length to monitoring head)	2 m (6x0,14 mm <sup>2</sup> ) / 6.56 ft (6x0.217·10 <sup>-3</sup> in. <sup>2</sup> )
	max. length	100 m / 328 ft
<sup>(1)</sup> Of the set value, at constant temperature and flow conditions, and stable thermal conductivity. <sup>(2)</sup> Delay with the switch point set to 1 m/s / 3.28 fps and the flow at 2 m/s / 6.56 fps, after a sudden complete stop. <sup>(3)</sup> Admissible operating pressure to DIN 2401, measured at the max. admissible temperature (= max. medium temperature)		

1

**Ordering information – Flow Monitor**

<b>Flow Monitor</b>	
<b>SFW209</b>	for liquids and gases, suitable for track mounting
<b>Input voltage</b>	
<b>AC 230 V</b>	50/60 Hz (230/240 V)
<b>AC 115 V</b>	50/60 Hz
<b>AC/DC 24 V</b>	
<b>SFW209</b>	<b>AC 230 V</b> ordering example

**Ordering Information – Monitoring head**

<b>Monitoring head (fitting thread)</b>	
<b>MK G1/2A</b>	
<b>MK 1/2"NPT</b>	
<b>Monitoring head material</b>	
<b>ST11</b>	only NPT thread
<b>ST12</b>	only G1/2A thread (standard)
<b>MK G1/2A - ST12</b>	ordering example

**SFW209 MKV push-in type monitoring head (see separate page)**

**Ordering information – Cable type 8 with connector**

<b>Cable and plug</b>	between monitoring head and control unit
<b>Do + Ka type 8</b>	7-pole round connector, PVC insulated cable type LiYCY 6x0,14 mm <sup>2</sup> /6x0.217·10 <sup>-3</sup> in. <sup>2</sup> , AWG 26, RAL 7032
<b>Available cable lengths</b>	
<b>...m</b>	2 m, 3 m, 5 m, 8 m, 10 m, 15 m, 20 m, 25 m, 30 m, 40 m, 50 m, 100 m (up to 100 m/328 ft)
<b>Do + Ka type 8 - 2 m</b>	ordering example

See data sheet monitoring head MKV.

**Flow ranges**

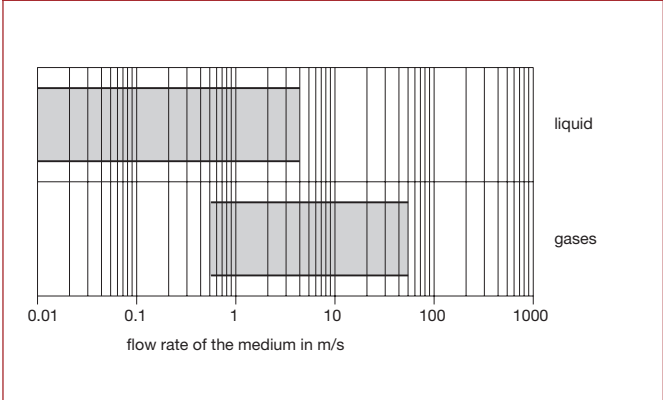

**Dimensions**

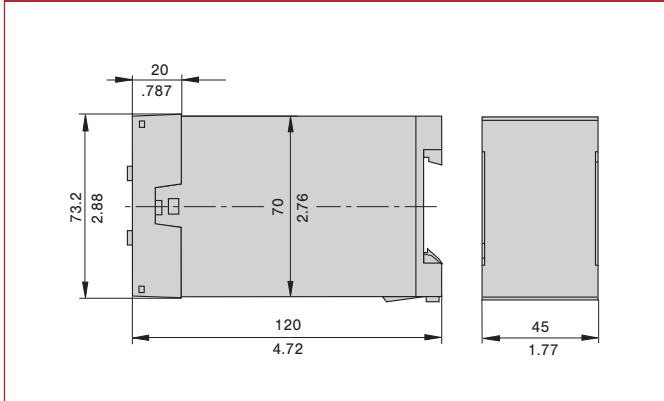

This is a metric design and millimeter dimensions take precedence ( $\frac{mm}{inch}$ )

**Connection diagram**

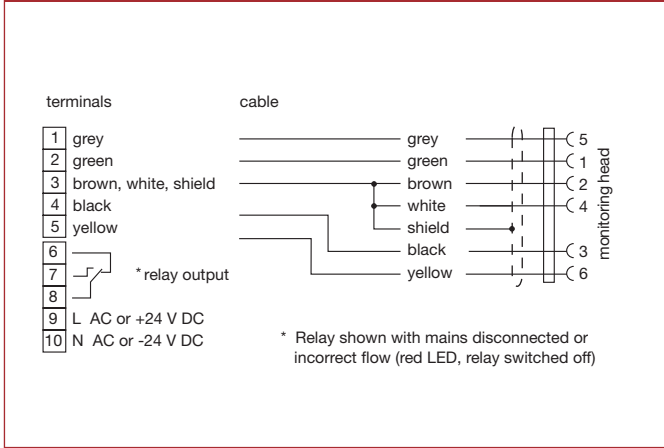

**Dimensions monitoring head**

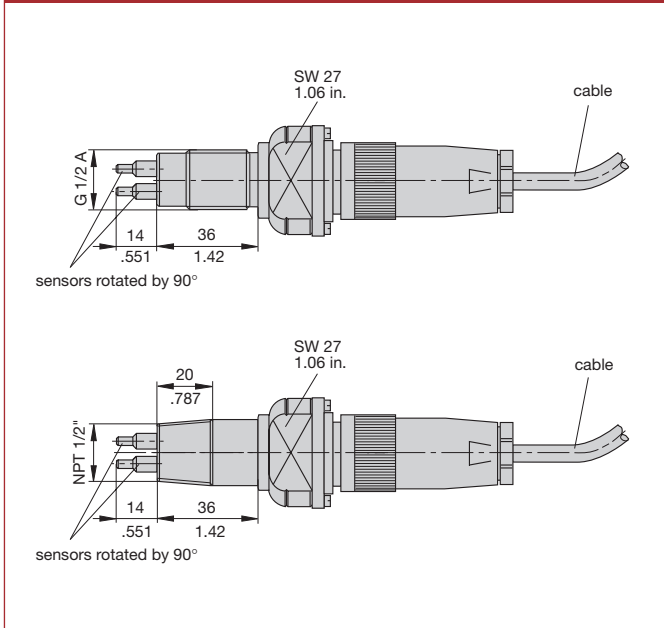

This is a metric design and millimeter dimensions take precedence ( $\frac{mm}{inch}$ )

All dimensions without tolerances are for reference only. In the interest of improved design, performance and cost effectiveness the right to make changes in these specifications without notice is reserved. Product markings may not be exactly as the ordering codes. Errors and omissions excepted.

**Description**

Extended calorimetric monitoring head with variable immersion depth for use in systems with larger pipe sizes (DN50 plus).

**Caution:** Fix with locking set 01 (see accessories).

**Features**

- Temperature range  
gases/liquids: -40 °C ... +100 °C
- Material: stainless steel 1.4571

**Calorimetric monitoring head**



**MKV-13**

**Ordering information**

<b>Type</b>	MKV	Push-in type monitoring head with calorimetric sensors
<b>Monitoring head design</b>	13	Monitoring head with variable immersion depth
<b>Medium</b>	X	Liquids and gases
<b>Material of areas exposed to medium</b>	M1	stainless steel 1.4571
<b>Process connection</b>	00	without flange; see accessories for cable gland **)
<b>Length of shank</b>	L30	300 mm/11.8 in. (standard) other lengths upon request
<b>Electrical connection</b>	E30	round connector Rd24, 7-pole (plug and cable to separate order)
<b>Certification</b>	T0	without certificate (standard) *)
<b>Specification of medium</b>	xxx	
MKV - 13 X M1 00 L30 E30 T0 - ... ordering example		

\*) for detailed information please see section 0.  
\*\*) see next page.

**Technical data**

Type of head	push-in
Nominal shank dia.	18 mm/0.709 in. (without thread)
Length of shank	300 mm/11.8 in.
Length of sensor	14 mm/0.551 in.
Suitable for	liquids and gases
Temperature range *) (of gases/liquids)	-40 °C ... +100 °C/-40 °F ... +212 °F
Pressure resistance (1) of sensor	100 bar/1450 psi
Pressure resistance (1) (installation)	25 bar/363 psi (with threaded installation bush)
Degree of protection (2)	IP67 (connector):
Material	stainless steel 1.457
Cable to electronic controlunit	Do + Ka type 2 – 2 m (up to max. 100 m/328 ft)
Weight	710 g/1.57 lb

(1) Admissible operating pressure DIN 2401, measured at max. temperature  
(= max. medium temperature)  
(2) with mating connector  
\*) max. +80 °C in the connector area

**Dimensions**

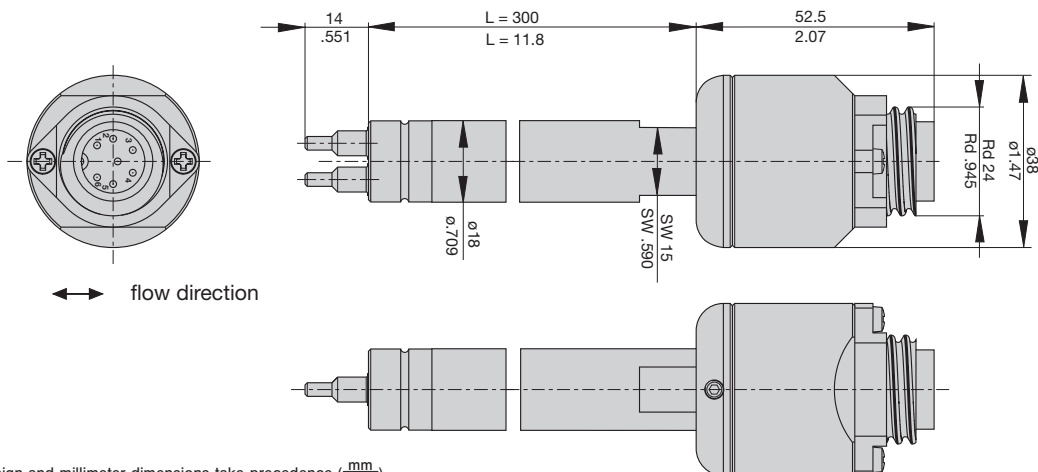

This is a metric design and millimeter dimensions take precedence ( $\frac{mm}{inch}$ )

**Cable type 8 with connectors**



1

**Description**

Cable between push-in type monitoring head MKV and flow monitor SFW209.

**Technical data**

**Cable type 8**

**Features:** flexible, fully shielded,  
electrical and thermal properties at +20 °C/+68 °F

Conductor resistance:	< 131 Ω/km
Insulation resistance:	> 200 MΩ
Operating voltage:	max. 350 V
Withstand voltage:	1200 V
Max. load:	1.5 A
Temperature range:	-10 °C ... +80 °C/+14 °F ... +176 °F (processing and operation) -30 °C ... +80 °C/-22 °F ... +176 °F (transport and storage)

**Ordering information**

<b>Cable and plug</b>	between monitoring head and control unit
<b>Do + Ka type 8</b>	7-pole round connector, PVC insulated cable type LiYCY 6x0,14 mm <sup>2</sup> /6x0.217·10 <sup>-3</sup> in. <sup>2</sup> , AWG 26, RAL 7032
<b>Available cable lengths</b>	
<b>...m</b>	2 m, 3 m, 5 m, 8 m, 10 m, 15 m, 20 m, 25 m, 30 m, 40 m, 50 m, 60 m, 70 m, 80 m, 90 m and 100 m (up to 100 m/328 ft)
<b>Do + Ka type 8 - 2 m</b>	ordering example

**Accessories**

**Threaded installation bush  
0Z122Z000196**

**Teflon sealing ring  
0Z122Z000197**

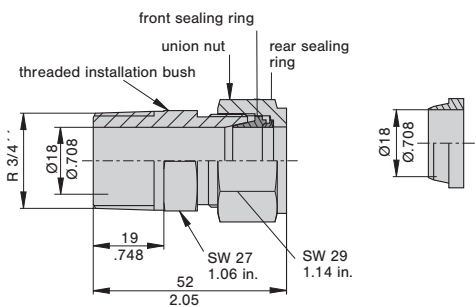

Suitable up to 25 bar/2.5 MPa/363 psi if used with stainless steel MK monitoring head.  
(Observe instructions for installation.)

**Caution:** Stainless steel ring is designed to cut into monitoring head.  
Pressure resistant to 25 bar/2.5 MPa/363 psi.  
Teflon ring can only be used from 0 to 2 bar/0,2 MPa/29 psi.  
Please observe user manual and safety guidelines!

**Locking set 01  
0Z122Z000204**

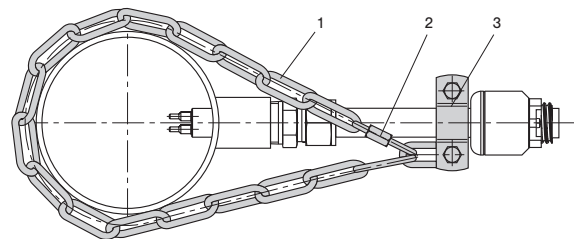

- 1 chain 4 x 32 DIN 5685 (approx. 1 m/3.28 ft)
- 2 catch for chain NG 5
- 3 clip with screw and nuts DN15 to DIN 11850

This is a metric design and millimeter dimensions take precedence ( $\frac{mm}{inch}$ )