

**FVone-NP-CA...00/22...
(Push-in type)**

Recommended for:
DN 65 and bigger

Required accessory:
Threaded installation bush
Cable type 31

Optional accessory:
PTFE sealing ring
Locking set

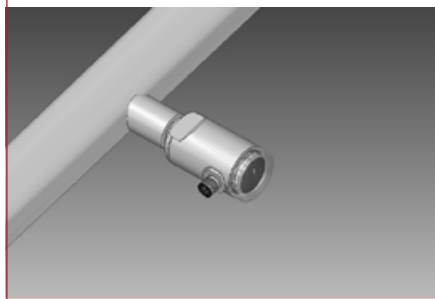
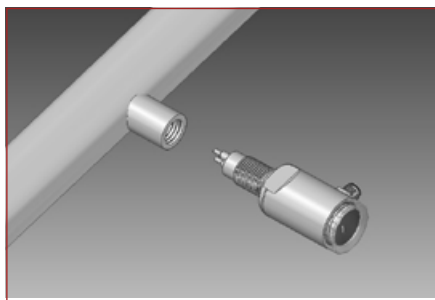

**FVone-NP-CA...01/02...
(Screw-in type)**

Recommended for:
DN 20 – DN 80

Required accessory:
Cable type 31

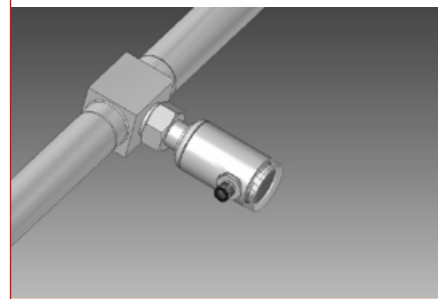
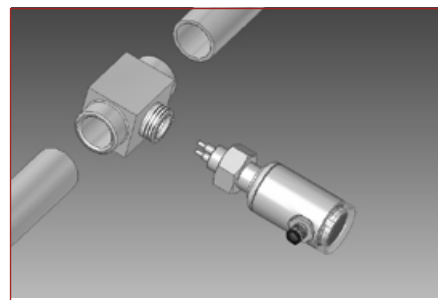

**FVone-NP-CA...11...
(Plug-in type)**

Recommended for:
DN 15 – DN 50

Required accessory:
Sensor adapter TP or
Ball valve BV
Cable type 31

Features

- Compact flow meter for air, compressed air, nitrogen, oxygen, argon, carbon dioxide, methane and hydrogen
- Measured values: standard volume flow/mass flow, standard flow speed, totalizer/consumption, temperature
- Wear-resistant compact design, with stainless steel monitoring head and housing
- Totalizer power fail-safe
- USB interface enables configuration, display of measured values and data logging by PC Software
Download: www.flowvision-gmbh.de/fvone-software_e
- 4...20 mA outputs for flow and temperature
- Pulse output
- Error indication output
- Two galvanically isolated relay outputs

Ordering information

Flow meter (calorimetric)

FVone FlowVision one

Housing

NP Compact housing

Firmware

CA Flow measurement of gases

Power supply

U1 DC 24 V

Process connection

00 Push-in type, L=300 mm, threaded installation bush as accessory

22 Push-in type, L=200 mm, threaded installation bush as accessory

01 Screw-in type, thread G1/2A (to DIN 3852-A), L =36 mm

02 Screw-in type, thread NPT1/2"-14, L=36 mm

11 Plug-in type (following DIN ISO 6149), L = 18,2 mm, for TP or BV adapters

Material (wetted parts)

M1 Stainless steel 1.4571 (standard material)

M2 Hastelloy C4 2.4610

M6 Titanium G7 3.7235

M14 Tantalum (coating 50 ± 20 µm), base material 1.4571, only with process connection 01 and 02

M... further materials upon request

Electrical connection

E25 M12x1, 12-pole

FVone- NP- CA- U1- 01- M1- E25 ordering example

Inspection Report and Inspection Certificate see chapter B.

A

1

2

3

4

5

6

7

8

9

10

11

12

13

14

15

16

17

18

19

20

21

22

23

24

25

26

27

B

C

TECHNICAL DATA (TU = 25 °C, UB = DC 24 V)

General Data			FVone
Suitable for			air, compressed air, nitrogen, oxygen, argon, carbon dioxide, methane, hydrogen, further gases upon request
Temperature range	fluid	all types	-25 °C ... +80 °C
		push-in type	-25 °C ... +185 °C with a distance of 20 cm between fluid and electronic housing
	ambience		-25 °C ... +150 °C with a distance of 15 cm between fluid and electronic housing
Configuration			via USB by PC software , runs on Windows® XP, Windows Vista®, Windows® 7, Windows® 8, Windows® 10 ⁽⁴⁾
Electrical data			
Input voltage U _B			DC 24 V (18 ... 32 V)
Power consumption			max. 180 mA
2 Analogue outputs	flow and temperature		4...20 mA (12 bit)
2 Relay outputs	flow or temperature		galvanically isolated, AC/DC 24 V, max. 0,7 A
2 Transistor outputs	Pulse output (consumption) and error indication output		Power Fet, high side switch, short circuit proof max. load 500 mA, inductive load max. 100 mA
Power indication			LED (green)
Connection			M12 connector, 12-pole
MTTF (SN 29500)			121 years
Flow measurement ⁽⁸⁾			
Measuring range 0...68 Nm ³ /s (operating range 0...100 Nm ³ /s) ^{(3) (7)}	Volume flow depends on inner pipe diameter	16 mm, TP-01	0...50 Nm ³ /h (0...72 Nm ³ /h)
		20 mm, TP-02	0...77 Nm ³ /h (0...113 Nm ³ /h)
		25 mm, TP/BV-03	0...120 Nm ³ /h (0...177 Nm ³ /h)
		32 mm, TP/BV-04	0...197 Nm ³ /h (0...289 Nm ³ /h)
		40 mm, TP/BV-05	0...308 Nm ³ /h (0...452 Nm ³ /h)
		50 mm, TP/BV-06	0...481 Nm ³ /h (0...707 Nm ³ /h)
		60 mm	0...692 Nm ³ /h (0...1018 Nm ³ /h)
		70 mm	0...942 Nm ³ /h (0...1385 Nm ³ /h)
		80 mm	0...1231 Nm ³ /h (0...1810 Nm ³ /h)
		90 mm	0...1557 Nm ³ /h (0...2290 Nm ³ /h)
		100 mm	0...1923 Nm ³ /h (0...2827 Nm ³ /h)
		120 mm	0...2769 Nm ³ /h (0...4072 Nm ³ /h)
		140 mm	0...3768 Nm ³ /h (0...5542 Nm ³ /h)
		160 mm	0...4922 Nm ³ /h (0...7238 Nm ³ /h)
		180 mm	0...6229 Nm ³ /h (0...9161 Nm ³ /h)
		200 mm	0...7691 Nm ³ /h (0...11310 Nm ³ /h)
		250 mm	0...12017 Nm ³ /h (0...17672 Nm ³ /h)
		300 mm	0...17304 Nm ³ /h (0...25447 Nm ³ /h)
		400 mm	0...30763 Nm ³ /h (0...45239 Nm ³ /h)
		500 mm	0...48066 Nm ³ /h (0...70686 Nm ³ /h)
600 mm	0...69216 Nm ³ /h (0...101788 Nm ³ /h)		
800 mm	0...123050 Nm ³ /h (0...180956 Nm ³ /h)		
1000 mm	0...192266 Nm ³ /h (0...282744 Nm ³ /h)		
1200 mm	0...276863 Nm ³ /h (0...407151 Nm ³ /h)		
1600 mm	0...492201 Nm ³ /h (0...723825 Nm ³ /h)		
2000 mm	0...769064 Nm ³ /h (0...1130976 Nm ³ /h)		
Accuracy ⁽²⁾	plug-in type	3 ... 50 % of measuring range	± 2,5 % of measured value ± 0,3 % of measuring range final value
		50 ... 100 % of measuring range	± 5 % of measured value ± 1 % of measuring range final value
	screw-in type/ push-in type	3 ... 50 % of measuring range	± 3 % of measured value ± 0,75 % of measuring range final value
		50 ... 100 % of measuring range	± 7 % of measured value ± 1 % of measuring range final value
Repeatability ⁽¹⁾			± 1 % of measured value ± 0,5 % of measuring range final value
Response time T ₆₃			5 s ⁽⁶⁾
Response time T ₉₀			8 s ⁽⁶⁾

TECHNICAL DATA (TU = 25 °C, UB = DC 24 V)

Temperature drift (+10 ... +70 °C)	± 0,04 % of measuring range final value/°C	
Pressure drift	approx. ± 0,5 % of measured value/bar	
Temperature Measurement		
Measuring range	-25 °C ... +185 °C	
Accuracy	± 1 % of measuring range ⁽⁵⁾	
Mechanical data		
Type and size of monitoring head	plug-in type	following DIN ISO 6149
	screw-in type	G 1/2 A, NPT 1/2"
	push-in type	shank diameter 18 mm, length 200 mm/300 mm
Pressure resistance of monitoring head	100 bar, higher pressures with Inspection Certificate 3.1, observe pressure resistance of installation	
Degree of protection	IP67 (when plugged in)	
Materials	fitting, sensor (wetted)	stainless steel 1.4571 (standard)
	connection sensor/fitting	laser welded
	housing	stainless steel 1.4571
	M12 connector	CuZn, nickel-plated
	cap	PA
Weight	o-rings	FKM (wetted, plug-in and push-in type)
	plug-in type	ca. 480 g
	screw-in type	ca. 420 g
	push-in type 200 mm	ca. 760 g
	push-in type 300 mm	ca. 910 g

⁽¹⁾ At constant temperature and flow conditions, and stable thermal conductivity.

⁽²⁾ The accuracy values were determined under ideal conditions: Symmetrical complete flow profile, correct mounting in the pipe, inlets and outlets according to manual.

⁽³⁾ Measuring range (operating range) for methane:

TP-01: 0...33 Nm³/h (0...72 Nm³/h)
 TP-02: 0...51 Nm³/h (0...113 Nm³/h)
 TP/BV-03: 0...80 Nm³/h (0...176 Nm³/h)
 TP/BV-04: 0...132 Nm³/h (0...289 Nm³/h)
 TP/BV-05: 0...206 Nm³/h (0...452 Nm³/h)
 TP/BV-06: 0...322 Nm³/h (0...706 Nm³/h)
 Screw-in/Push-in type: 0...46 Nm/s (0...100 Nm/s) - Nm³/h depends on pipe diameter, see table

Measuring range (operating range) for hydrogen:

TP-01: 0...29 Nm³/h (0...62,3 Nm³/h)
 TP-02: 0...45,2 Nm³/h (0...97,3 Nm³/h)
 TP/BV-03: 0...70,7 Nm³/h (0...152 Nm³/h)
 TP/BV-04: 0...116 Nm³/h (0...249 Nm³/h)
 TP/BV-05: 0...181 Nm³/h (0...389 Nm³/h)
 TP/BV-06: 0...283 Nm³/h (0...608 Nm³/h)
 Screw-in/Push-in type: 0...40 Nm/s (0...86 Nm/s) - Nm³/h depends on pipe diameter, see table

⁽⁴⁾ Requires .NET Framework 4 (is provided for free by Microsoft®, usually already installed) and Windows® with current updates

⁽⁵⁾ At constant flow rate; fast changes of flow rate may temporarily cause greater deviation than stated.

⁽⁶⁾ Measured at a flow of 20 Nm/s after a sudden complete stop.

⁽⁷⁾ Valid up to 12 bar abs., > 12 bar abs. upon request.

⁽⁸⁾ Specifications in Nm³/h and Nm/s refer to 1013 mbar, 0°C. Sensor calibration is performed at approx. 25 °C and approx. 970 mbar abs. in TP-03, inside pipe diameter 29,7 mm (screw-in type) and inside pipe diameter 79,2 mm (push-in type) respectively.

Windows and Windows Vista are either registered trademarks or trademarks of Microsoft Corporation in the United States and/or other countries.

PC Software

A
1
2
3
4
5
6
7
8
9
10
11
12
13
14
15
16
17
18
19
20
21
22
23
24
25
26
27
B
C

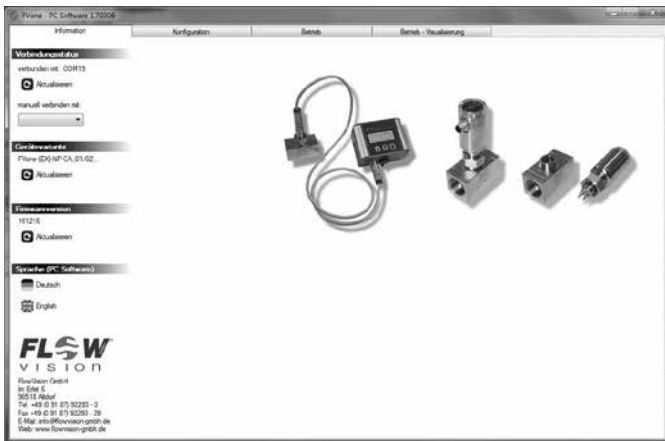

Information/General settings:

- Information about the connected device (type, firmware)
- Connection status
- Selection of application language

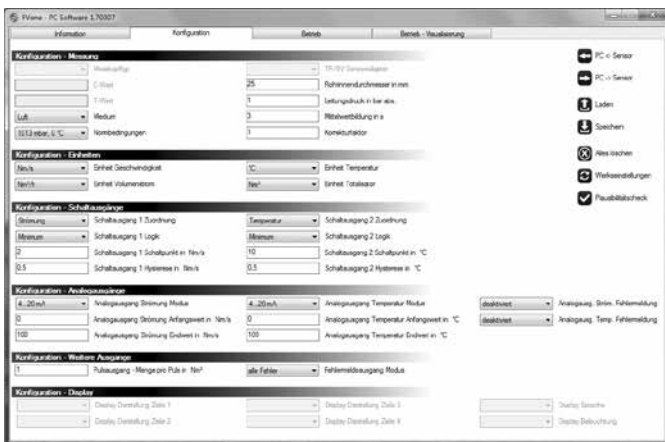

Configuration:

- Basic settings (fluid, standard conditions, inside pipe diameter, averaging...)
- Selection of units for volume flow, speed, totalizer, temperature
- Configuration of analogue outputs, switching outputs, pulse output and error indication output
- Loading and saving the configuration to the hard disk
- Plausibility check
- Call up factory settings



Operation:

- Recording of measured values – export to Microsoft® Excel®
- Setting of the readout interval, 2 s up to 100000 s (= approx. 27 hours)
- Shows the actual measured values (volume flow, speed, totalizer, temperature)
- Shows the maximum and minimum values
- Shows the state of the switching and the error indication output
- Setting of the low flow suppression and execution of the zero point adjustment
- Shows which error occurred last
- Resetting of the totalizer value, the minimum and maximum values and the last error

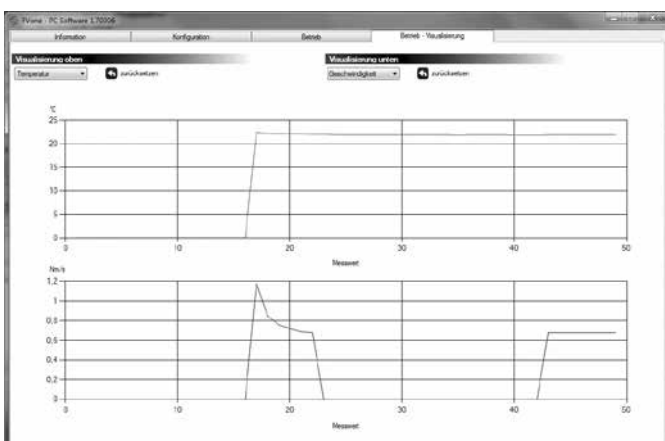

Visualisation:

- Chart of the measured values volume flow, speed and temperature (maximum two simultaneously)

Microsoft and Excel are either registered trademarks or trademarks of Microsoft Corporation in the United States and/or other countries.

Measuring and operating ranges

The measuring/operating ranges are determined by the inner pipe diameter.
They can be calculated with the following equation:

$$Q = V_N \times A_R$$

Q (Nm³/h) - flow quantity

V_N (Nm/h) - average standard velocity

A_R (m²) - inner pipe cross section

Standard velocity measuring range (air, nitrogen, oxygen, argon, carbon dioxide):	0 ... 68 Nm/s
Standard velocity measuring range (methane):	0 ... 46 Nm/s
Standard velocity measuring range (hydrogen):	0 ... 40 Nm/s
Standard velocity operating range (air, nitrogen, oxygen, argon, carbon dioxide, methane):	0 ... 100 Nm/s
Standard velocity operating range (hydrogen):	0 ... 86 Nm/s

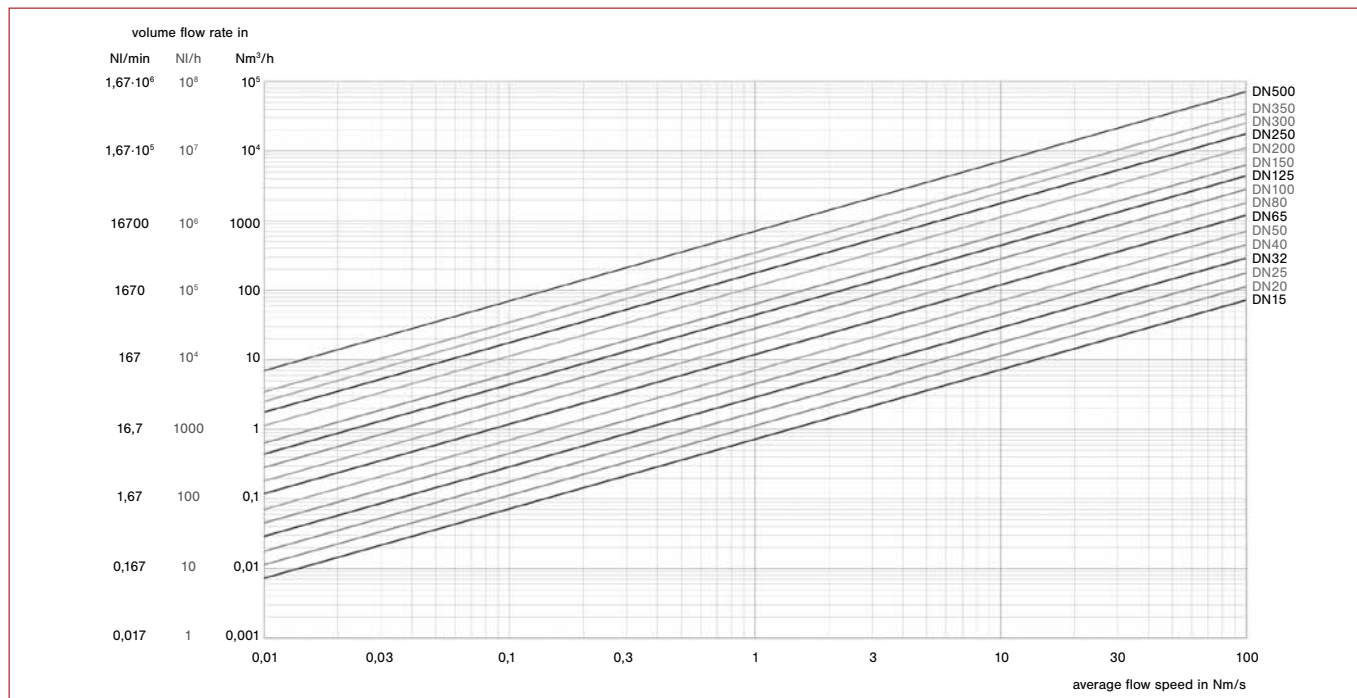

A

1

2

3

4

5

6

7

8

9

10

11

12

13

14

15

16

17

18

19

20

21

22

23

24

25

26

27

B

C

Electrical connection

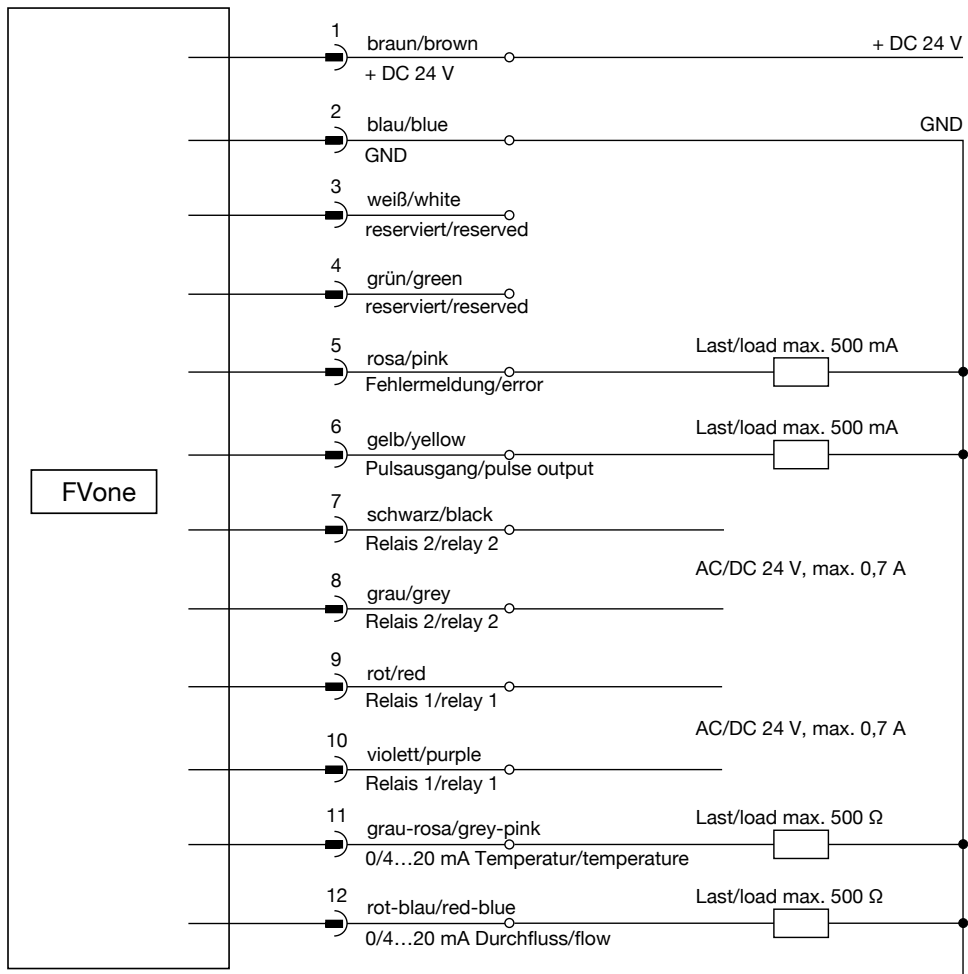

Connector top view

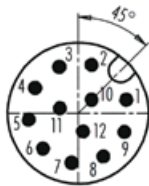

- A
- 1
- 2
- 3
- 4
- 5
- 6
- 7
- 8
- 9**
- 10
- 11
- 12
- 13
- 14
- 15
- 16
- 17
- 18
- 19
- 20
- 21
- 22
- 23
- 24
- 25
- 26
- 27
- B
- C

Dimensions

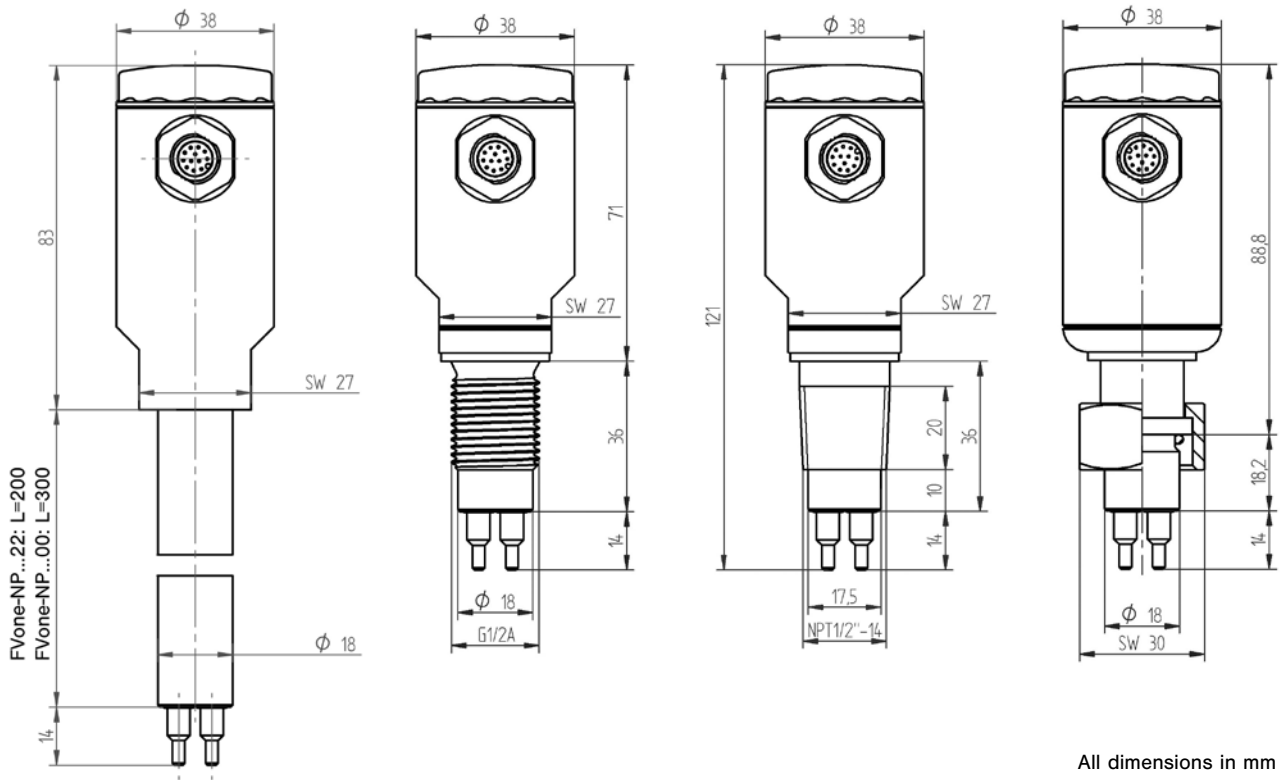

All dimensions without tolerances are for reference only. In the interest of improved design, performance and cost effectiveness the right to make changes in these specifications without notice is reserved. Product markings may not be exactly as the ordering codes. Errors and omissions excepted.

Sensor adapter TP/Ball valve BV

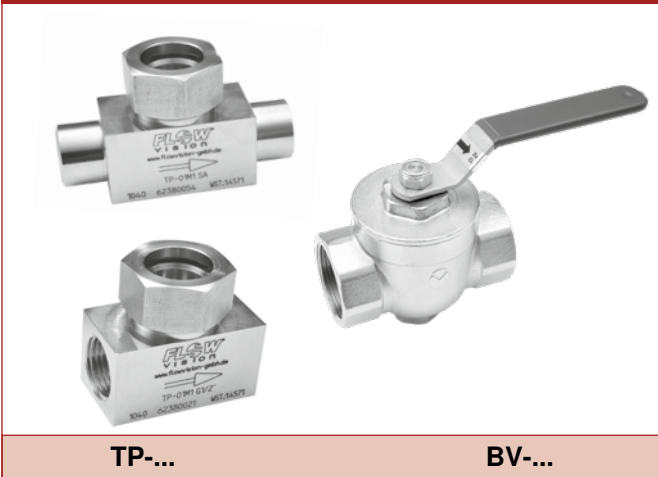

TP-...

BV-...

Features

- Correct positioning of sensor
- Ease of sensor replacement
- Measuring point can be closed if not used
- Sensor adapter available as screw-in or welding type
- Ball valve also serves as a shutoff valve (both input and out output)

Accessories

Description	Ref. No.
Blanking plug, brass, with O ring	0Z121Z000186
Union nut, brass	Y 306 901 01
Blanking plug, stainless steel 1.4571/AISI 316 Ti, with viton O ring	0Z121Z000187
Union nut, stainless steel	Y 306 901 03

Description

Sensor adapters TP and BV facilitate correct positioning and exchange of FVone...11... (plug-in type connection) in pipes with process connection DN 15...DN 50.

Ball valve BV enables pressure-free installation or removal of FVone...11... (plug-in type connection) simply by closing the input and output pipe. The measuring points are suited to temporary measurements; after completion of the measuring cycle they can be closed by means of blanking plugs.

Ordering information – sensor adapter TP/thread

Type	
TP	Sensor adapter with internal thread
Process connection/Nominal size	
01	DN 15 G1/2 internal thread length: 50 mm/1.97 in.
02	DN 20 G3/4 internal thread length: 64 mm/2.52 in.
03	DN 25 G1 internal thread length: 78 mm/3.07 in.
04	DN 32 G1 1/4 internal thread length: 94 mm/3.70 in.
05	DN 40 G1 1/2 internal thread length: 110 mm/4.33 in.
06	DN 50 G2 internal thread length: 138 mm/5.43 in.
Material of the area exposed to fluid	
M1	stainless steel 1.4571/AISI 316Ti PN 315 bar/4570 psi
M3	brass (not TP-03..) PN 25 bar/363 psi
M5	red brass (only TP-03..) PN 16 bar/232 psi
TP - 01	M3 ordering example

Ordering information – sensor adapter TP/welding

Type	
TP	Sensor adapter with welding nipples
Process connection/Nominal size	
01	DN 15 dia.d: 16 mm/.630 in. length: 80 mm/3.15 in.
02	DN 20 dia.d: 20 mm/.787 in. length: 70 mm/2.76 in.
03	DN 25 dia.d: 25 mm/.984 in. length: 80 mm/3.15 in.
04	DN 32 dia.d: 32 mm/1.26 in. length: 100 mm/3.94 in.
05	DN 40 dia.d: 40 mm/1.57 in. length: 110 mm/4.33 in.
06	DN 50 dia.d: 50 mm/1.97 in. length: 140 mm/5.51 in.
Material of the area exposed to fluid	
M1	stainless steel 1.4571/AISI 316Ti
Process connection	
SA	welded connection
TP - 01	M1 - SA ordering example

Ordering information – ball valve

Type	
BV	ball valve with internal thread
Process connection/Nominal size	
03	DN 25 G1 internal thread length: 88 mm/3.46 in.
04	DN 32 G1 1/4 internal thread length: 100 mm/3.94 in.
05	DN 40 G1 1/2 internal thread length: 110 mm/4.33 in.
06	DN 50 G2 internal thread length: 131 mm/5.16 in.
Material of the area exposed to fluid	
M3	nickel plated brass, Delrin seal
BV - 03	M3 ordering example

Dimensions

TP-... sensor adapter with internal thread

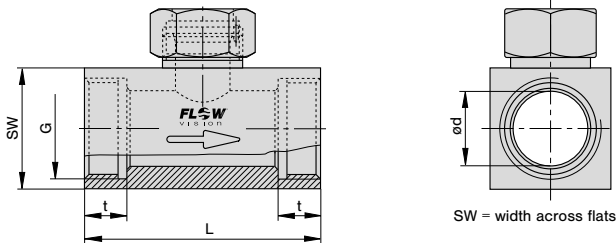

Material stainless steel (-M1): PN 315 bar / 4569 psi
 Material brass (-M3): PN 25 bar / 363 psi
 Material red brass (-M5): PN 16 bar / 232 psi

Type	DN		dia. d		G	t		L		SW	
	mm	in.	mm	in.	in.	mm	in.	mm	in.	mm	in.
TP-01 ...	15	.591	16	.630	1/2"	11	.433	50	1.97	27	1.06
TP-02 ...	20	.787	20	.787	3/4"	12	.472	64	2.52	32	1.26
TP-03 ...	25	.984	25	.984	1"	14	.551	78	3.07	40	1.57
TP-04 ...	32	1.26	32	1.26	1.1/4"	15	.591	94	3.70	50	1.97
TP-05 ...	40	1.57	40	1.57	1.1/2"	15	.591	110	4.33	55	2.16
TP-06 ...	50	1.97	50	1.97	2"	19	.748	138	5.43	70	2.76

TP-... M1-SA sensor adapter with welding nipples

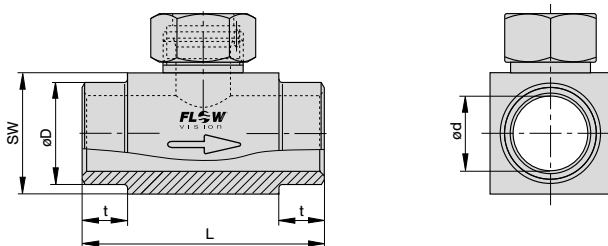

PN 315 bar / 4569 psi

Type	DN		dia. d		dia. D		t		L		SW	
	mm	in.	mm	in.	mm	in.	mm	in.	mm	in.	mm	in.
TP-01M1-SA	15	.591	16	.630	21.3	.839	15	.591	80	3.15	27	1.06
TP-02M1-SA	20	.787	20	.787	26.9	1.06	15	.591	70	2.76	32	1.26
TP-03M1-SA	25	.984	25	.984	33.7	1.33	15	.591	80	3.15	40	1.57
TP-04M1-SA	32	1.26	32	1.26	42.4	1.67	15	.591	100	3.94	50	1.97
TP-05M1-SA	40	1.57	40	1.57	48.3	1.90	15	.591	110	4.33	55	2.16
TP-06M1-SA	50	1.97	50	1.97	60.3	2.37	15	.591	140	5.51	70	2.76

BV-... M3 Ball valve with internal thread

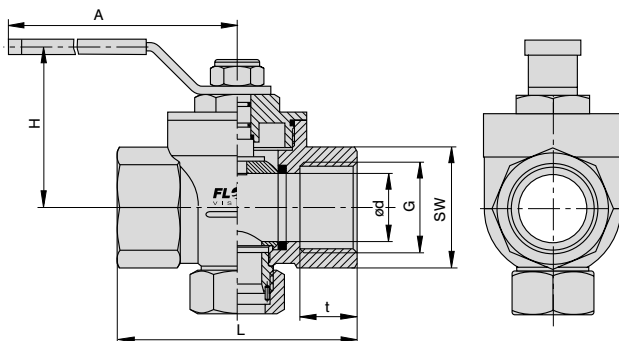

PN 25 bar / 363 psi

Type	DN		dia. d		G	t		L		SW		H		A	
	mm	in.	mm	in.	in.	mm	in.	mm	in.	mm	in.	mm	in.	mm	in.
BV-03M3	25	.984	25	.984	1"	21	.827	88	3.47	41	1.61	59	2.32	115	4.53
BV-04M3	32	1.26	32	1.26	1.1/4"	24	.945	100	3.94	50	1.97	65	2.56	115	4.53
BV-05M3	40	1.57	40	1.57	1.1/2"	24	.945	110	4.33	54	2.13	77	3.03	150	5.91
BV-06M3	50	1.97	50	1.97	2"	28	1.10	131	5.16	70	2.76	85	3.35	150	5.91

This is a metric design and millimeter dimensions take precedence (mm/inch)

A

1

2

3

4

5

6

7

8

9

10

11

12

13

14

15

16

17

18

19

20

21

22

23

24

25

26

27

B

C

Compression fitting

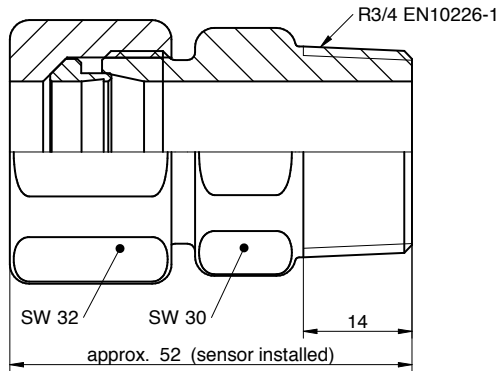

Description and ordering information

Compression fitting for push-in sensors with R3/4 thread

Compression fitting for push-in sensors

EEF	Compression fitting		
	Process connection		
	04	Thread R3/4	
		Material double nipple and cap nut	
		M1	Stainless steel 1.4571
		M2	Hastelloy C4 2.4610
		Material clamping ring	
		CR1	Stainless steel 1.4571 PN 25 bar abs.
		CR2	PTFE PN 5 bar abs.
		CR3	Hastelloy C4 2.4610 PN 25 bar abs.
EEF -	04 -	M1 -	CR1 ordering example

Hygiene flange

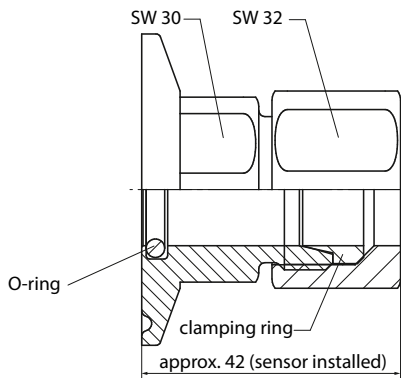

Description and ordering information

Hygiene flange for push-in sensors with front-flush o-ring with FDA approval

Hygiene flange for push-in sensors

HEF	Hygiene flange		
	Process connection		
	TF1	Triclamp DIN 32676	
		Material flange and cap nut	
		M1	Stainless steel 1.4571
		M2	Hastelloy C4 2.4610
		O-ring	
		R1	VMQ (Silicone) blue FDA (standard)
		R2	VMQ (Silicone) white FDA
		Material clamping ring	
		CR1	Stainless steel 1.4571 PN 25 bar abs.
		CR2	PTFE PN 5 bar abs.
		CR3	Hastelloy C4 2.4610 PN 25 bar abs.
HEF -	TF1 -	M1 -	R1 - CR1 ordering example

Locking set

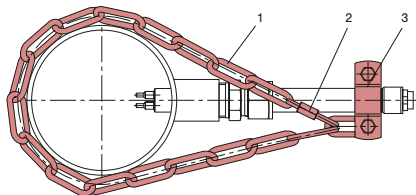

Description and ordering information

Locking set for push-in sensors.

- 1 Chain 4 x 32 DIN 5685 (approx. 1 m)
- 2 Catch for chain NG 5
- 3 Clip with screw and nuts DN15 to DIN 11850

Ordering no.: 0Z122Z000204

Ball valve for installation under pressure

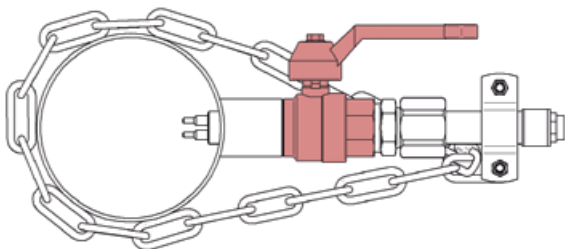

Description and ordering information

Material (body, ball): Brass nickel plated	Material (body, ball): Stainless steel 1.4408, 1.4401
Material (ball seal): PTFE	Material (ball seal): PTFE
Length: 65 mm	Length: 78 mm
Outside thread: G3/4", L = 13 mm	Outside thread: R3/4", L = 17 mm
Inside thread: G3/4", L = 15 mm	Inside thread: Rp3/4", L = 13 mm
Fluid temperature: -20...120 °C	Fluid temperature: -30...180 °C
Ambient temperature: 0...80 °C	Ambient temperature: 0...80 °C
Pressure: PN 25 bar (up to 80 °C)	Pressure: PN 64 bar (up to 80 °C)
Ordering number: BV-02M3-PI	Ordering number: BV-02M15-PI

Mobile power adapter 24 V DC for FVone-NP



Description

Wall plug transformer with 1,6 m cable and connector, 12-pole, M12-A for power supply of FVone-NP and configuration of the sensor before installation.

Attention: No output signals available.

Ordering no.: Z00040

Stainless steel cap

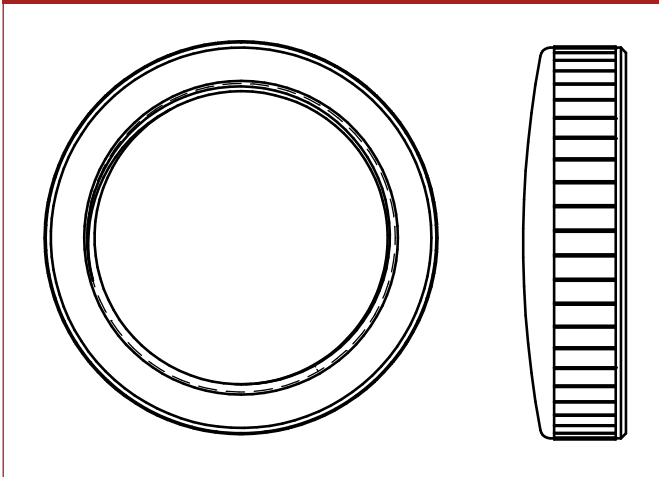

Description

Protective cap, material stainless steel 1.4571

Ordering no.: Z00025

A

1

2

3

4

5

6

7

8

9

10

11

12

13

14

15

16

17

18

19

20

21

22

23

24

25

26

27

B

C

Cable type 31 with connector

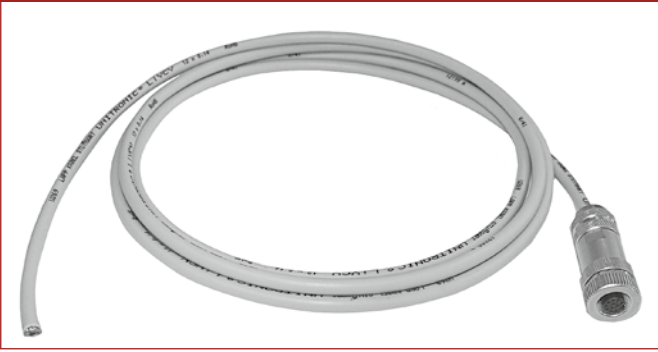

Technical data

Degree of protection:	IP67 (only if connector plugged in)
Temperature range:	-30 °C ... +80 °C
Insulation resistance (cable):	≥ 20 MΩ x km
Withstand voltage (cable):	1200 V
Bending radius:	116 mm

Description

Shielded connecting cable with PVC jacket and metal connector M12 for flow meter FVone-NP for electrical connection of supply voltage and outputs.

Ordering information

Type

Do + Ka Type 31 PVC insulated cable 12x0,25 mm², shielded with metal connector, 12-pole, M12-A

... m available cable lengths: 2m, 5m, 10m, 15m, 20m, ..., 100m (in 10m steps)

Do + Ka Type 31 - 5 m ordering example

Cable type 32 with connector



Technical data

Degree of protection:	IP67 (only if connector plugged in)
Temperature range:	-25 °C ... +80 °C
Insulation resistance:	> 10 ⁸ Ω
Bending radius:	100 mm

Description

Shielded connecting cable with halogen free PUR jacket and plastic connector M12 for flow meter FVone-NP for electrical connection of supply voltage and outputs.

Ordering information

Type

Do + Ka Type 32 PUR insulated cable 12x0,14 mm², shielded with plastic connector, 12-pole, M12-A

... m available cable lengths: 5m, 10m

Do + Ka Type 32 - 5 m ordering example