

Description

Velocity sensors MSZ214 and MSZ218 are electro-magnetic transducers with self excitation. MSZ214 has a diameter of 14 mm (M14 thread) and MSZ218 a diameter of 18 mm (M18 thread).

Features

- Contactless sensing of mechanical motion such as the rotational speed of drives or shafts.
- Pulses are generated by the movement of ferrous gear teeth, for example, as they pass the sensor head.
- The electronic control circuitry and sensor head are designed as an integral unit.
- The electronic control circuitry is reverse polarity protected.
- A digital output is available corresponding to the frequency of movement past the sensor.
- Connection by 2 m permanent cable

Mode of operation

A ferro magnet actuator such as a gear, screw-head or slot in a shaft, passes near to the sensor face, causing the magnetic field to change such that voltage is induced in the coil of the sensor. This voltage is converted into a digital output signal by means of a comparator and made available to the user via a transistor output. The output frequency is directly proportional to the actuator speed.

As this principle is based on voltage induction, the actuator needs to have a certain minimum circumferential speed in order to induce a voltage high enough to be evaluated. A rotational motion from "zero" speed cannot therefore be detected (see diagram "Operating range" on next page). The benefit of this principle is the high upper frequency limit of 20 kHz.

Ordering information

Type No.	
MSZ	Inductive Velocity Sensor
214	diameter/thread M14x1
218	diameter/thread M18x1
Version	
M	stainless steel 1.4305/AISI 303
Output signal	
1	open collector 40 V/40 mA
Connection	
A	2 m cable, with open end
MSZ 214 - M 1 A	ordering example

Output

Digital frequency output

Output frequency $f_{out} = Z \times n/60$ (Hz)

Z = number of teeth on the pick-up
n = rotational speed of the pick-up in 1/min (rpm)

Open collector - NPN

$U_{max} = 40$ V
 $I_{max} = 40$ mA

With integral overload protection.



MSZ

Technical data

Mechanical data:	
Outer thread	metric
MSZ214	M 14x1
MSZ218	M 18x1
Housing	stainless steel 1.4305/AISI 303
Max. tightening torque	50 Nm with MSZ214 100 Nm with MSZ218
Max. pull out force (connection cable)	50 N
Max. pressure (sensor face)	10 bar/145 psi
Degree of protection (IEC 529/DIN 40050)	IP67
Vibration	±0.76 mm (55 Hz), to IEC 60068-2-6; 10 frequency cycles/axis
Shock	30 g (11 ms) to IEC 60068-2-27
Connection	2 m three-wire cable
Temperature ranges:	
with cable permanently connected	-30 ... +85 °C/-22 ... +185 °F
sensor face area	-30 ... +125 °C/-22 ... +257 °F
Voltage supply:	
U_b	DC 5 V...36 V

Notes:

The max. admissible residual ripple is 10 %, but not less than the minimum voltage or more than the maximum voltage. The supply voltage has no influence on the minimum required actuator speed and the useful frequency range of the sensor.

Supply current (without load):

I_o ($U_b = 5$ V) 5 mA
 I_o ($U_b = 36$ V) 8 mA

Electrical tests:

ESD - test to VDE 0834-2, class 3
EMC - test to IEC 60065(sec)96,
class 3 a ($U_b \geq 15$ V); class 3 b ($U_b < 15$ V)

Actuator/Operating range

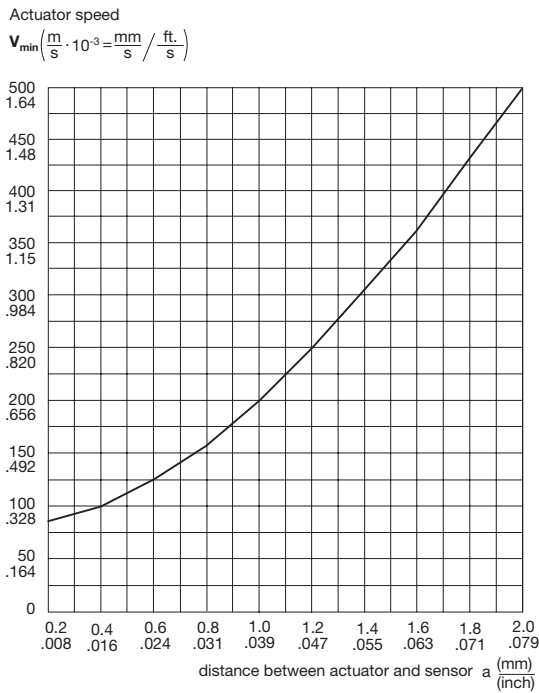

Connection diagrams

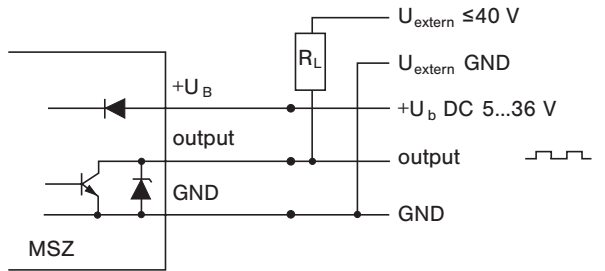
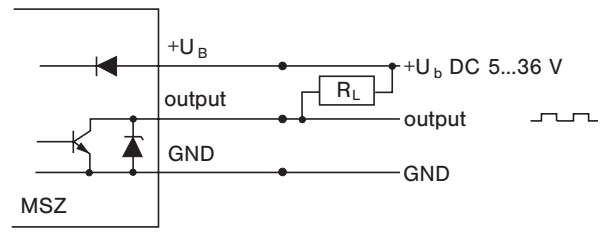

A

- 1
- 2
- 3
- 4
- 5
- 6

- 7
- 8
- 9

The minimum actuator speed V_{min} that can be measured by the sensor is a function of distance a (between sensor and pick-up). The function of the sensor is largely independent of the pick-up geometry. A minimum distance between the teeth of approx. 2.5 mm should be observed. The max. frequency processed by the sensor is 20 kHz.

Dimensions

MSZ214-M1A

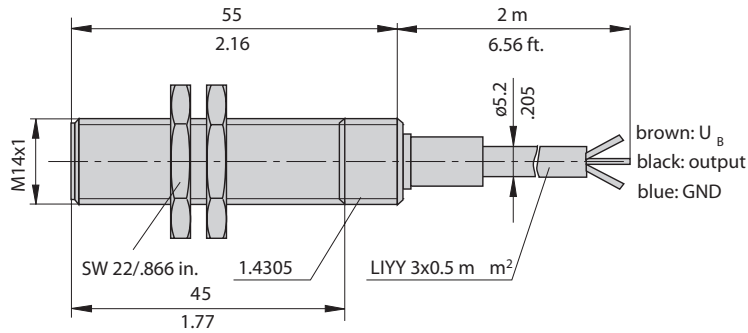

MSZ218-M1A

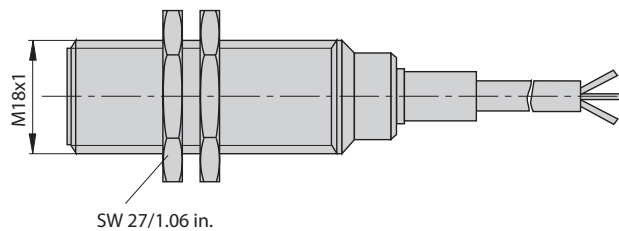

B

This is a metric design and millimeter dimensions take precedence ($\frac{mm}{inch}$)

All dimensions without tolerances are for reference only. In the interest of improved design, performance and cost effectiveness the right to make changes in these specifications without notice is reserved. Product markings may not be exactly as the ordering codes. Errors and omissions excepted.